

**Electronic Engine Controls
by Glendinning
Handheld Remote Control Option
Installation & Operation Guide**



Glendinning Marine Products, Inc.
740 Century Circle
Conway, SC 29526
(843) 399-6146
Fax: (843) 399-5005
www.glendinningprods.com

Chapters at a Glance

1.0	Overview	3
1.1	System Description and Capabilities	5
1.2	System Components	5
2.0	Installation Procedure	7
2.1	Mounting Handheld Auxiliary Function Output Unit	9
2.2	Hooking Up Handheld Remote	9
2.2.1	Hard-Wired Installation	9
2.2.2	Plug-In Installation	9
2.3	Power Supply	10
3.0	Operation	11
3.1	Normal Keypad Functions	13
3.2	Optional Push-Button Functions	13
4.0	Technical Documents	15
4.1	Handheld Remote Dimensions	17
4.2	Handheld Auxiliary Function Output Unit Dimensions	18
4.3	Handheld Auxiliary Function Output Unit Pinout Descriptions	19
4.4	Wiring Layout	20



Section 1.0 — Overview

1.1—System Description & Capabilities

1.2—System Components



1.1 System Description & Capabilities

The Glendinning Handheld Remote Control Option gives boat operators total control of both transmission and throttle from virtually anywhere on the boat. This portable control station puts the same operational features of our fixed control station in your hands for easier docking and maneuvering of your boat. The Glendinning Handheld Remote Option incorporates the following features:



- **NEW! CANbus Technology** — With CANbus technology, communication components are more robust, wiring is simplified, and installation is made easier.
- **Ergonomic Design** — Our design fits more comfortably in your hands than any other remote control option on the market. The “game pad” style design allows you to effortlessly control both engines at the same time.
- **Complete Control** — All normal Glendinning operating functions available at any fixed control station are available on the Handheld Remote. Keypad appearance is the same eliminating steep learning curve.
- **Additional Functions Available** — Up to 5 other propulsion functions can be added to the Handheld Remote — Engine Stop or Start, Bow or Stern Thruster, and Rudder Control.
- **Wiring Options** — Choose either to “hard-wire” the Handheld Remote to the control system or install pluggable connectors for multi-location control anywhere on your boat — the ultimate in Handheld Remote convenience.



DO NOT EXPOSE THE HANDHELD REMOTE CONTROL TO WATER.

ALTHOUGH THE REMOTE CONTROL UNIT IS WATERTIGHT, IT IS NOT WATER-PROOF.

EXTREME CARE SHOULD BE TAKEN WHEN STORING AND HANDLING THE REMOTE CONTROL UNIT.

EXPOSING THE HANDHELD REMOTE CONTROL UNIT TO UNDUE MOISTURE CAN RENDER THE UNIT INOPERABLE AND CANCEL THE WARRANTY. GLENDINNING WILL NOT BE LIABLE FOR ANY PROBLEMS INCURRED AS A RESULT.

1.2 System Components

The Glendinning Handheld Remote Control Option consists of the following components:

Handheld Remote Control

The Handheld Remote Control unit was designed to fit more naturally in your hands. Why have a remote control if it is awkward to operate? We designed our Handheld Remote after “PC game pads” giving the boat operator a better handle on our product.

The Glendinning Handheld Remote Control is by far the most informative remote in the industry today. The remote control keypad has integrated switches and indicator lights which allow the boat operator to control all aspects of the boat’s propulsion system — just like our fixed control stations.

Robust, watertight construction is a hallmark at Glendinning — we build our products to withstand the extreme conditions that exist in the marine environment (see warning in right margin).

Handheld Auxiliary Function Output Unit

The Handheld Auxiliary Function Output Unit receives commands from the Handheld Remote Control (when “active”) and operates the 5 optional propulsion functions as indicated (Engine Stop or Start, Bow or Stern Thruster, and/or Rudder Control). Optional functions are activated by depressing one of the 5 buttons surrounding the Handheld Remote key-

HANDHELD REMOTE KEYPAD (Close-up)



OPTIONAL FUNCTION BUTTONS

GEAR / THROTTLE CONTROL

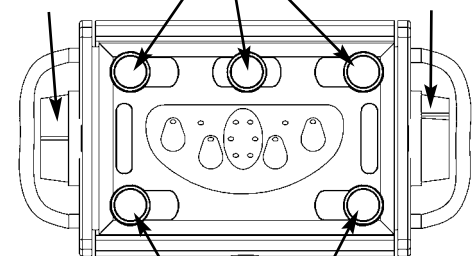

OPTIONAL FUNCTION BUTTONS



pad.

The Handheld Auxiliary Function Output Unit is “plug and play” ready which means you don’t have to spend valuable time trying to figure out how to connect the interface box to your boat’s optional features. The Interface Box may be installed near the Glendinning EEC Control Processor or near any control head station to make interfacing with other control options easier.

The Handheld Auxiliary Function Output Unit is completely watertight to protect the electronics from moisture which could render the optional functions inoperable.

Station Communication Wiring

Glendinning’s station cables are pre-terminated at the factory for ease of installation, and are completely shielded to eliminate problems caused by electromagnetic interference, complying with the latest and strictest standards in the industry. Both ends of the station cable have a connector which is identical on either end—no mistakes when it comes to plugging in the cable.

Depending on the method you choose to connect the Handheld Remote to the system, a terminating resistor may be necessary to complete the CANbus network.

Altering the communication cables or harnesses from their original condition when shipped will void the warranty and Glendinning will not be held liable for any problems incurred. If custom cables are required — contact GMP.

INSTALLATION SHOWING “HARD-WIRED” AND PLUGGABLE HANDHELD REMOTE STATIONS

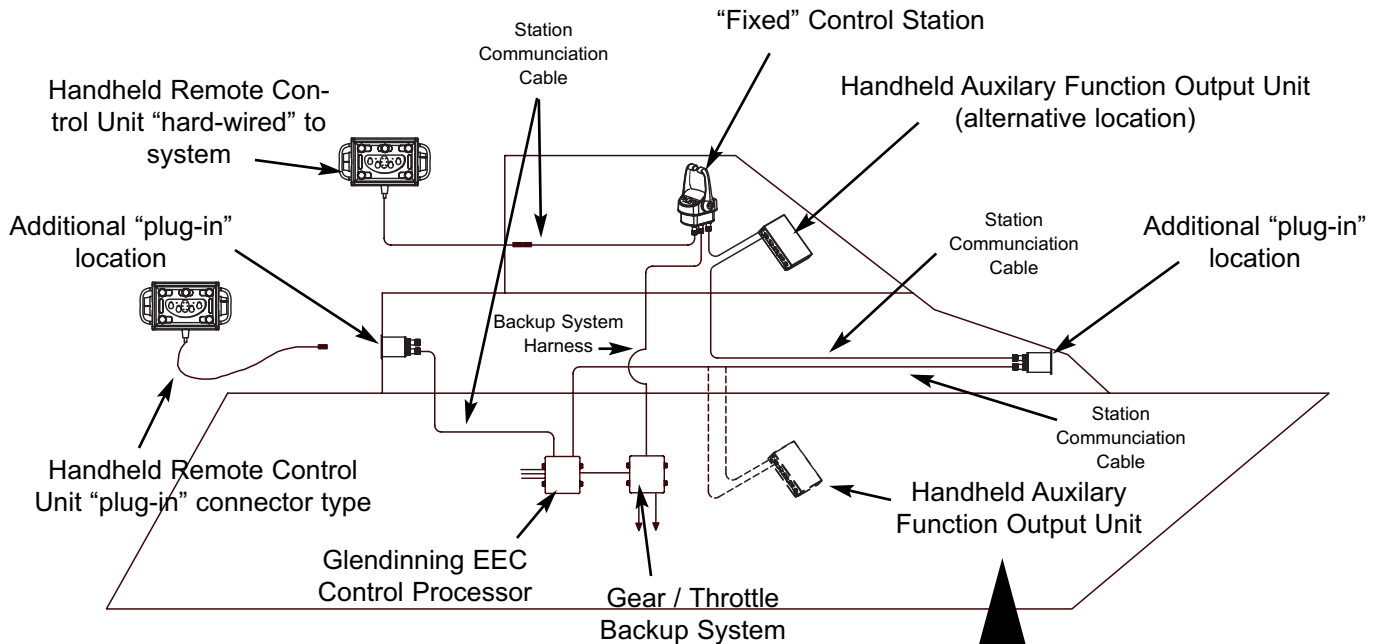

The Handheld Auxiliary Function Output Unit communicates between the handheld control buttons and the control circuits for bow or stern thruster, engine start or shutdown, and / or rudder control and can be located in the engine compartment near the control processor or near any control station where interfacing with other control functions is easier.

Section 2.0 — Installation Procedure

2.1—Mounting Handheld Auxiliary Function Output Unit

2.2—Hooking Up Handheld Remote Unit

2.3—Power Supply



2.1 Mounting Handheld Auxiliary Function Output Unit



Due to CANbus technology, installation of the Handheld Remote Control components is straightforward and easy. Careful consideration should be given to the mounting location of the Handheld Auxiliary Function Output Unit. The Handheld Auxiliary Function Output Unit communicates between the buttons on the Handheld Remote and the control circuits for bow or stern thrusters, engine start or stop, and rudder control.

Mount the Handheld Auxiliary Function Output Unit in a location where it would be easy to interface with other control functions. In some applications, the engine compartment would be an ideal location, however in other applications, installation near any of the other control stations would be more suitable. The Handheld Auxiliary Function Output Unit comes with a short connection cable to connect it to the Control Processor or control station (longer lengths available).

The mounting location should be protected from direct exposure to water or excessive heat.

- Determine which location best fits your installation application.
- Mount the Handheld Auxiliary Function Output Unit securely attaching it to the boat's structure using (4) 1/4" (7mm) machine bolts or lag screws.
- Connect communication cable from Handheld Auxiliary Function Output Unit to Control Processor or Control Station.

2.2 Hooking Up Handheld Remote

There are two methods for hooking up the Handheld Remote Unit—"hard-wired" or "plug-in" connection for multi-location access.

2.2.1 "Hard-wired" Installation

"Hard-wired" installation means that the Handheld Remote Control unit will remain in the location where it is installed. The location is determined by the proximity of a "fixed" control station. The Handheld Remote Control unit is connected to the bottom of the "fixed" control station allowing the boat operator to travel along a path within the 30' (longer lengths available) distance of the communication cable.

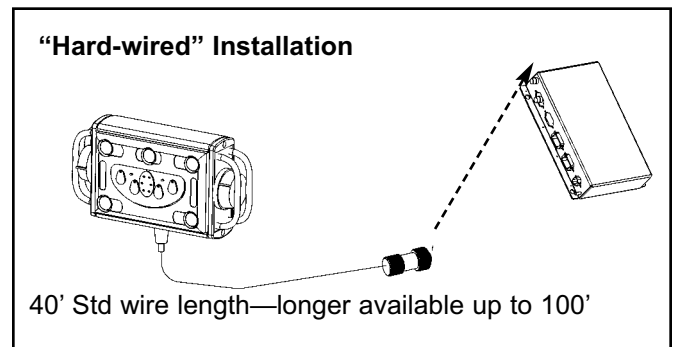

- Determine location where Handheld Remote is to be used (must be in close proximity to a "fixed" control station).
- Attach the Station Communication Cable from the Handheld Remote unit to the station connection plug on the bottom of the "fixed" control head.

2.2.2 "Plug-in" Installation

"Plug-in" installation allows the boat operator to install "plug-in" connectors along the station communication network's path where the Handheld Remote unit would be used. To move from one station "plug-in" point to the other, make sure Handheld Remote unit is INACTIVE and remove communication cable from plug.

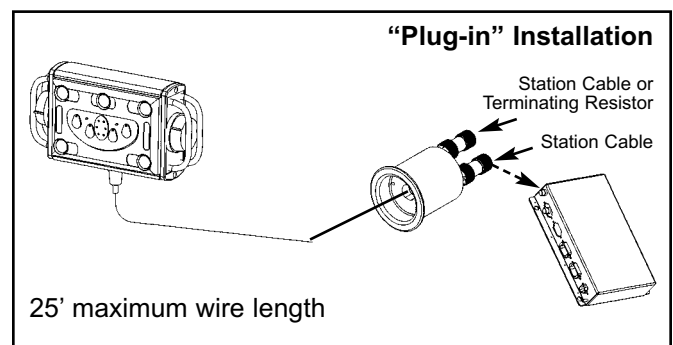



- Determine location where Handheld Remote is to be used.
- Install GMP PN 11472-EEC3 Handheld Pluggable Receptacle where access location is required.
 - Connect Handheld Pluggable Receptacle to CANbus Network using a communication “T” fitting. This “T” fitting MUST be located within 1 meter of the Handheld Pluggable Receptacle.
- Install a Terminating Resistor at one end of the “T” fitting if Handheld Pluggable Receptacle is at the end of the CANbus Network communication path. You DO NOT need a Terminating Resistor if the “T” fitting is connected to the Network path BETWEEN two communication stations.
- Replace the Handheld Pluggable Receptacle cap when Handheld Remote Control is “unplugged” from receptacle. This prevents moisture from harming the system.

2.3 Power Supply

The auxiliary switches on the Handheld Remote unit actuate relays in the Handheld Auxiliary Function Output Unit. These relays are for various switch functions (i.e. engine start or shutdown, bow or stern thrusters, or rudder control). In order to power these relays, battery input is required (12VDC or 24VDC).

To connect Interface Box to battery input:

- Connect the DC Power Harness (GMP PN 11601-01) to the Handheld Auxiliary Function Output Unit (see below).
- Connect the other end of the power harness to two separate battery positives and one common battery negative (12VDC or 24VDC) see illustration below.

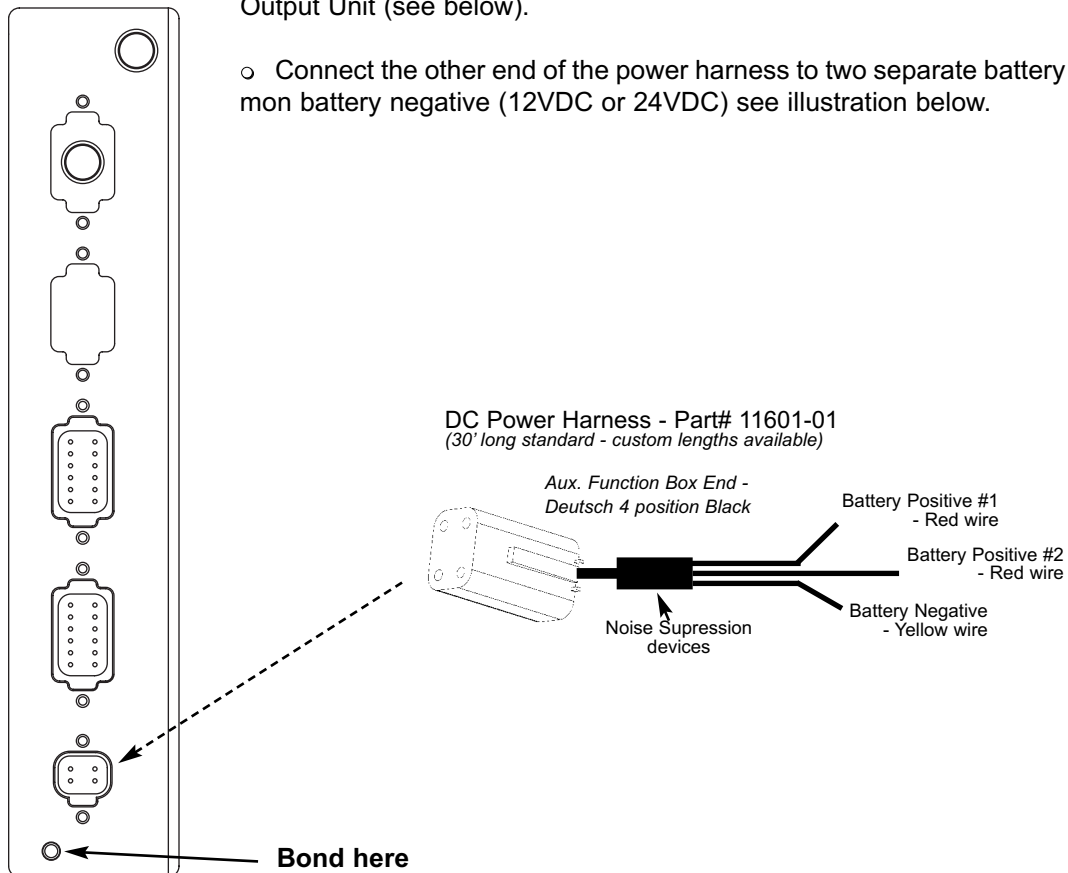

Section 3.0 — Operating the Handheld Remote Unit

3.1—Normal Keypad Functions

3.2—Optional Push-button Functions



3.1 Normal Keypad Functions

Operating the Handheld Remote is just as easy as operating any Glendinning “fixed” control station. The Handheld Remote unit will constantly monitor various parameters and will alert the boat operator if the system falls outside the normal operating range, just like the “fixed” control stations.



For detailed information on the normal keypad functions, consult your EEC-3 Installation & Operations Manual.

3.2 Optional Auxiliary Functions

The Glendinning Handheld Remote Control option also allows for the operation of auxiliary functions (i.e. engine startup or shutdown, bow or stern thrusters, and rudder control) from push-buttons located on the face of the Remote Control unit.

These push-button switches interface with existing auxiliary equipment and are momentary type—which means that to activate the appropriate function you must hold down the push-button as long as you want the operation to continue. Releasing the push-button will discontinue function operation.

You may choose which functions the Handheld Remote Control unit will operate, however, Engine Shutdown function is MANDATORY.

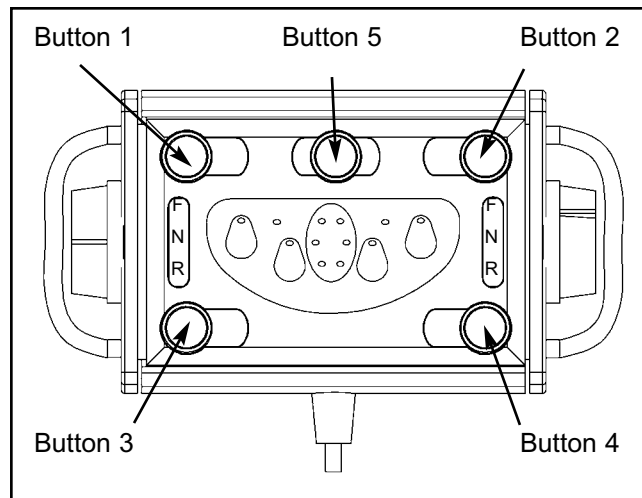

To connect auxiliary functions:

- For Engine Startup / Shutdown — consult your engine or boat manufacturer for more information.
- For Bow or Stern Thruster — consult your thruster’s manufacturer for more information.
- For Rudder Control — consult your autopilot manufacturer for more information.

Section 4.0 — Technical Documents

4.1—Handheld Remote Dimensions

4.2—Handheld Auxiliary Function Output Unit Dimensions

4.3—Handheld Auxiliary Function Output Unit Pinout Descriptions

4.4—Wiring Layout



4.1 Handheld Remote Dimensions

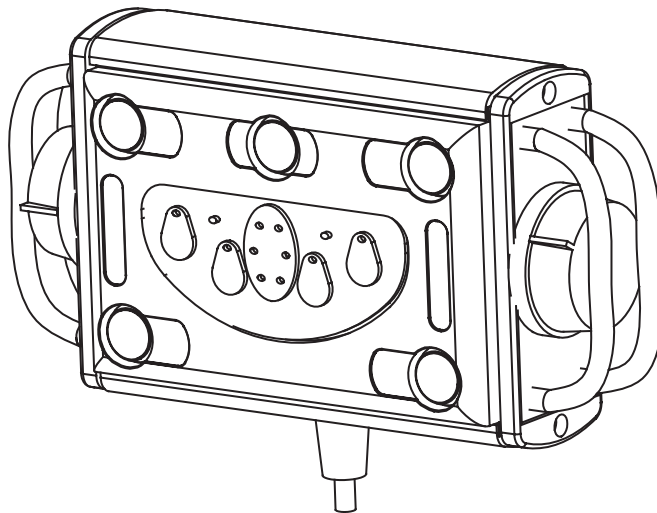
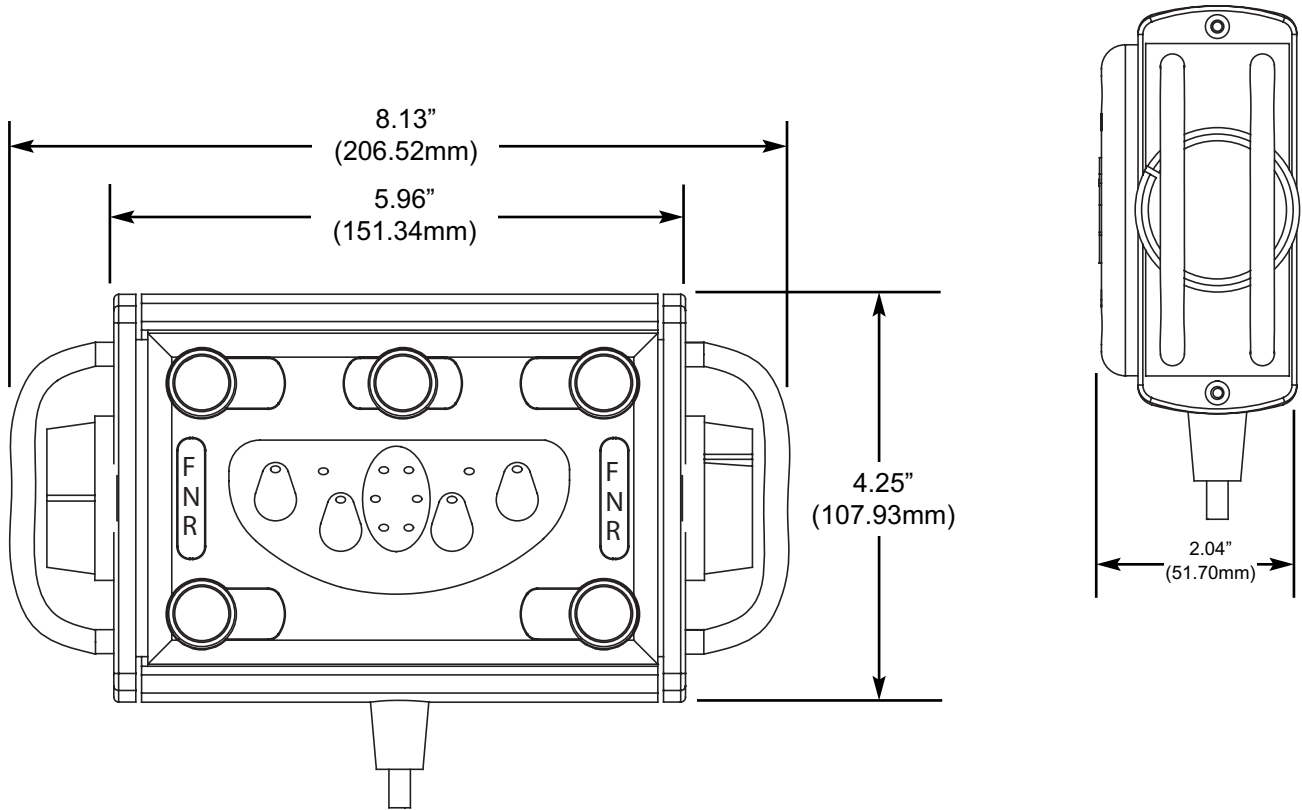

4.2 Handheld Auxiliary Function Output Unit Dimensions

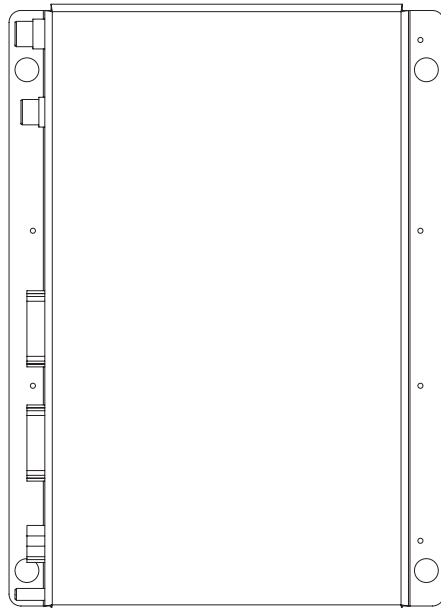
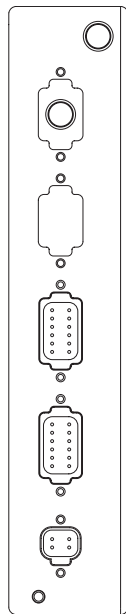
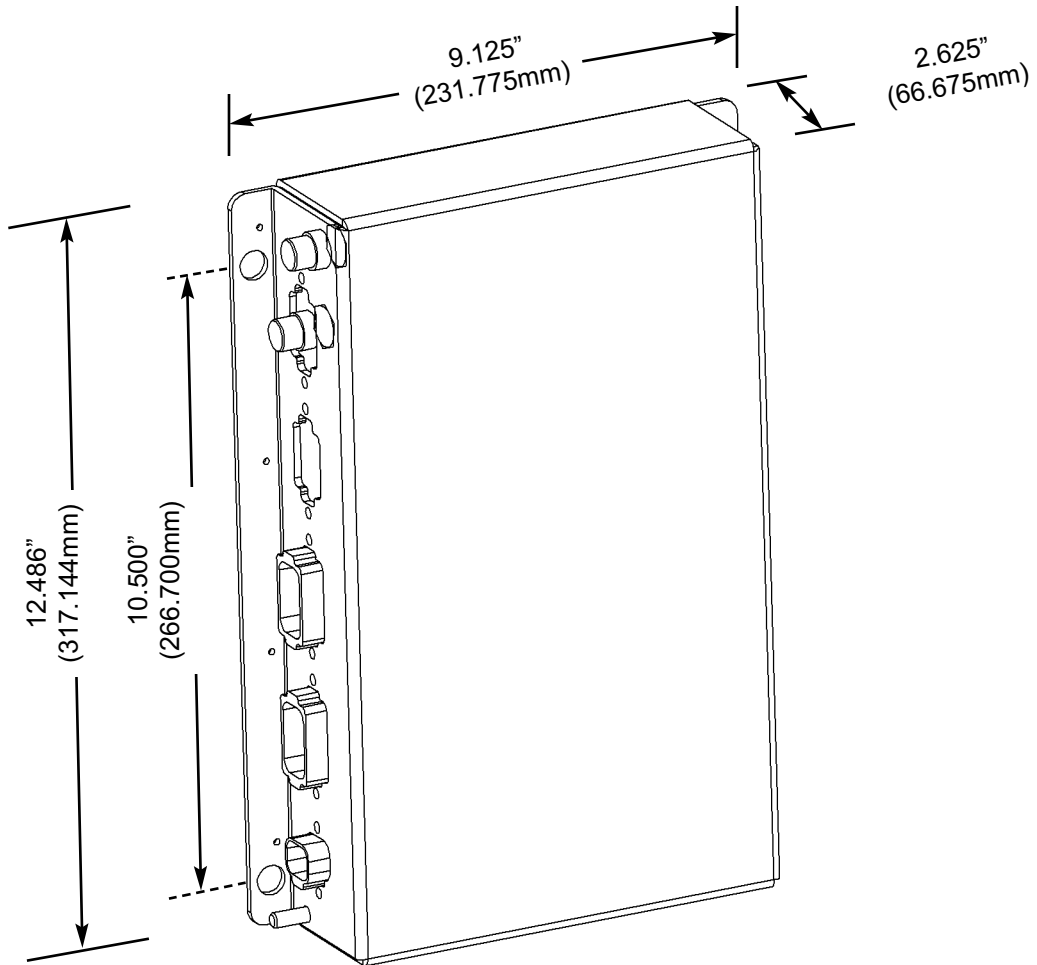

4.3 Handheld Auxiliary Function Output Unit Pinout Description

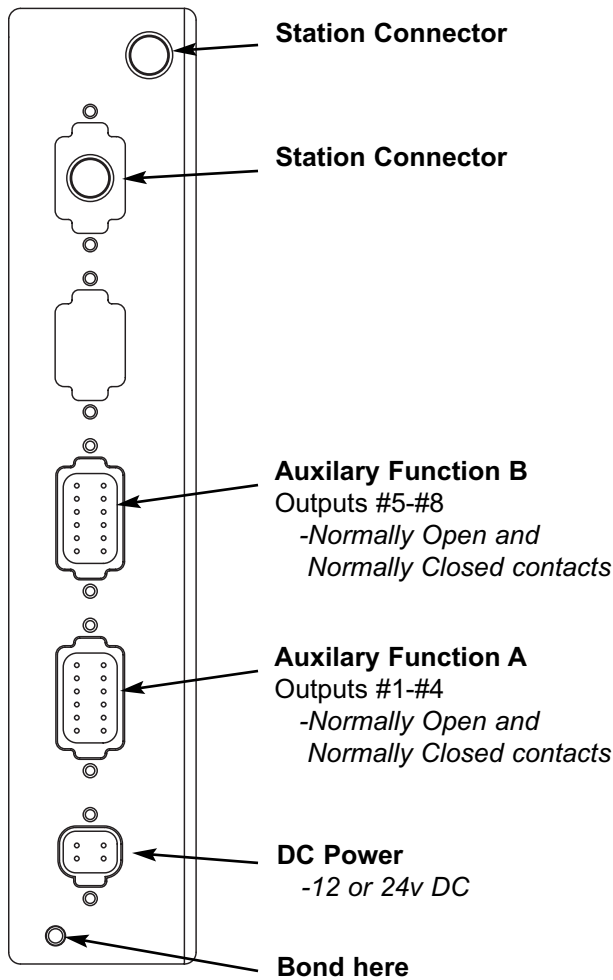

DC Power Connections	
12 or 24v DC	
Connector Pin	
1	Battery Positive #1
2	Battery Positive #2
3	Battery Positive #3

NOTE: Only one power input is required. Second power input is for redundancy.

Auxiliary Output Connections				
	Aux. Function Output	Connector Pin #		
		Common	NO	NC
Aux. Function #1-4 Connector	1	1	2	3
	2	4	5	6
	3	7	8	9
	4	10	11	12
Aux. Function #5-8 Connector	5	1	2	3
	6	4	5	6
	7	7	8	9
	8	10	11	12

NOTE: Harnesses are normally shipped for Normally Open contacts. See above to pin harness for Normally Closed contacts.

Aux. Function Output Harnesses

- used for outputs #1-4 and #5-8 outputs
- Harness pinned for Normally Open outputs
- Can be changed in the field for Normally Closed outputs
- Installer must fuse connections accordingly
- Relay contacts 12amp 30vDC resistive

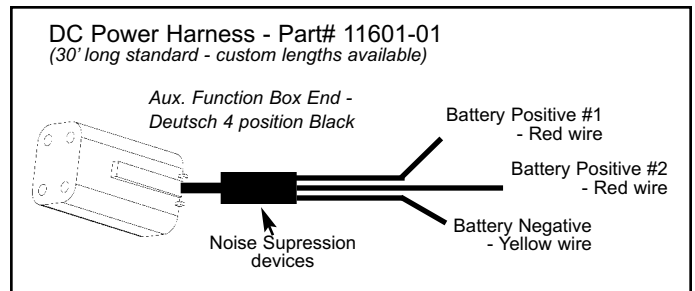
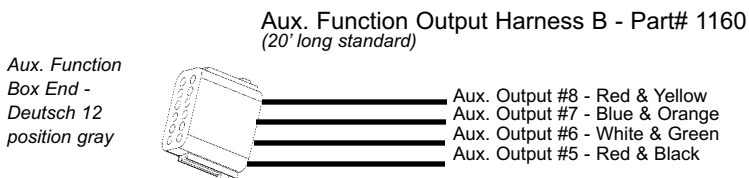
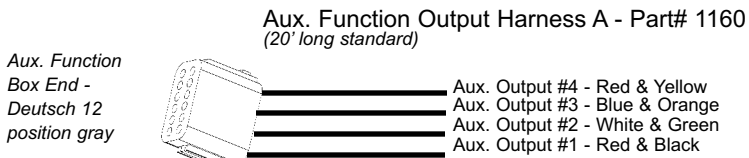

4.4 Wiring Layout

